

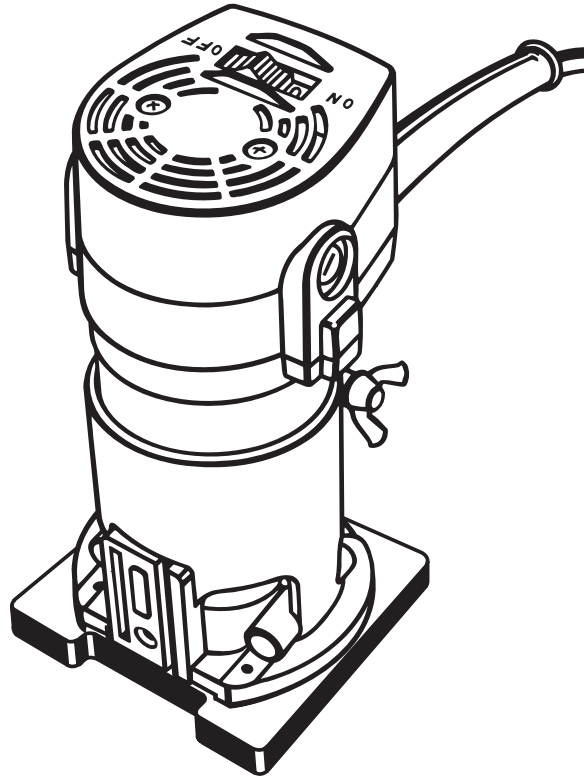

OPERATOR'S MANUAL LAMINATE TRIMMER MODEL TR31-1 DOUBLE INSULATED



SPECIFICATIONS:	
Maximum Cutter Diameter	1-3/8 in. (34.9 mm)
Collet	1/4 in. (6.4 mm)
Horsepower	3/4
Rating	120 volts, 60 Hz AC only, 3.8 amperes
No Load Speed	23,000 RPM
Power Cord	10 ft. (3 m)
Net Weight	3.0 lbs. (1.4 kg.)

We have engineered and manufactured your new Laminate Trimmer to Ryobi's high standard for dependability, ease of operation, and operator safety. When properly cared for, the Laminate Trimmer will give you years of rugged, trouble-free performance.

WARNING: Carefully read through this entire operator's manual before using your new trimmer.

Thank you again for buying Ryobi tools.

SAVE THIS MANUAL FOR FUTURE REFERENCE

TABLE OF CONTENTS

■ Introduction	2
■ General Safety Rules	3-4
■ Specific Safety Rules	4
■ Symbols	5
■ Unpacking	6
■ Features	6-7
■ Adjustments	7-8
■ Operation	9-11
■ Maintenance	12
■ Accessories	13-15

INTRODUCTION

DOUBLE INSULATION

Your Ryobi power tool is double insulated. Double insulation is a concept in safety, in electric power tools, which eliminates the need for the usual three-wire grounded power cord. All exposed metal parts are isolated from internal metal motor components with protecting insulation. Double insulated tools do not need to be grounded.

IMPORTANT

Servicing of a tool with double insulation requires extreme care and knowledge of the system and should be performed only by a qualified service technician. For service we suggest you return the tool to your nearest **RYOBI AUTHORIZED SERVICE CENTER** for repair. When servicing use only identical Ryobi replacement parts.

WARNING:

The double insulated system is intended to protect the user from shock resulting from a break in the tool's internal wiring. Observe all normal safety precautions related to avoiding electrical shock.

WARNING:

Do not attempt to operate this tool until you have read thoroughly and understand completely all instructions, safety rules, etc. contained in this manual. Failure to comply can result in accidents involving fire, electric shock, or serious personal injury. Save operator's manual and review frequently for continuing safe operation, and instructing others who may use this tool.

WARNING:



The operation of any laminate trimmer can result in foreign objects being thrown into your eyes, which can result in severe eye damage. Before beginning power tool operation, always wear safety goggles or safety glasses with side shields and a full face shield when needed. We recommend Wide Vision Safety Mask for use over eyeglasses or standard safety glasses with side shields. Always wear eye protection which is marked to comply with ANSI Z87.1.



Look for this symbol to point out important safety precautions. It means attention!!! Your safety is involved.

GENERAL SAFETY RULES



WARNING:

Read and understand all instructions. Failure to follow all instructions listed below, may result in electric shock, fire and/or serious personal injury.

SAVE THESE INSTRUCTIONS

Work Area

- **Keep your work area clean and well lit.** Cluttered benches and dark areas invite accidents.
- **Do not operate power tools in explosive atmospheres, such as in the presence of flammable liquids, gases, or dust.** Power tools create sparks which may ignite the dust or fumes.
- **Keep bystanders, children, and visitors away while operating a power tool.** Distractions can cause you to lose control.

Electrical Safety

- **Double insulated tools are equipped with a polarized plug (one blade is wider than the other). This plug will fit in a polarized outlet only one way. If the plug does not fit fully in the outlet, reverse the plug. If it still does not fit, contact a qualified electrician to install a polarized outlet. Do not change the plug in any way.** Double insulation eliminates the need for the three wire grounded power cord and grounded power supply system.
- **Avoid body contact with grounded surfaces such as pipes, radiators, ranges and refrigerators.** There is an increased risk of electric shock if your body is grounded.
- **Don't expose power tools to rain or wet conditions.** Water entering a power tool will increase the risk of electric shock.
- **Do not abuse the cord. Never use the cord to carry the tools or pull the plug from an outlet. Keep cord away from heat, oil, sharp edges or moving parts. Replace damaged cords immediately.** Damaged cords increase the risk of electric shock.
- **When operating a power tool outside, use an outdoor extension cord marked "W-A" or "W".** These cords are rated for outdoor use and reduce the risk of electric shock.

Personal Safety

- **Stay alert, watch what you are doing and use common sense when operating a power tool. Do not use tool while tired or under the influence of drugs, alcohol, or medication.** A moment of inattention while operating power tools may result in serious personal injury.
- **Dress properly. Do not wear loose clothing or jewelry. Contain long hair. Keep your hair, clothing, and gloves away from moving parts.** Loose clothes, jewelry, or long hair can be caught in moving parts.

- **Avoid accidental starting. Be sure switch is off before plugging in.** Carrying tools with your finger on the switch or plugging in tools that have the switch on invites accidents.
- **Remove adjusting keys or wrenches before turning the tool on.** A wrench or a key that is left attached to a rotating part of the tool may result in personal injury.
- **Do not overreach. Keep proper footing and balance at all times.** Proper footing and balance enables better control of the tool in unexpected situations.
- **Use safety equipment. Always wear eye protection.** Dust mask, nonskid safety shoes, hard hat, or hearing protection must be used for appropriate conditions.

Tool Use and Care

- **Use clamps or other practical way to secure and support the workpiece to a stable platform.** Holding the work by hand or against your body is unstable and may lead to loss of control.
- **Do not force tool. Use the correct tool for your application.** The correct tool will do the job better and safer at the rate for which it is designed.
- **Do not use tool if switch does not turn it on or off.** Any tool that cannot be controlled with the switch is dangerous and must be repaired.
- **Disconnect the plug from the power source before making any adjustments, changing accessories, or storing the tool.** Such preventive safety measures reduce risk of starting the tool accidentally.
- **Store idle tools out of reach of children and other untrained persons.** Tools are dangerous in the hands of untrained users.
- **Maintain tools with care. Keep cutting tools sharp and clean.** Properly maintained tools with sharp cutting edges are less likely to bind and are easier to control.
- **Check for misalignment or binding of moving parts, breakage of parts, and any other condition that may affect the tool's operation. If damaged, have the tool serviced before using.** Many accidents are caused by poorly maintained tools.
- **Use only accessories that are recommended by the manufacturer for your model.** Accessories that may be suitable for one tool, may become hazardous when used on another tool.

Service

- **Tool service must be performed only by qualified repair personnel.** Service or maintenance performed by unqualified personnel could result in a risk of injury.
- **When servicing a tool, use only identical replacement parts. Follow instructions in the Maintenance section of this manual.** Use of unauthorized parts or failure to follow Maintenance Instructions may create a risk of electric shock or injury.

GENERAL SAFETY RULES

- **Keep the tool and its handle dry, clean, and free from oil and grease.** Always use a clean cloth when clean

ng. Never use brake fluids, gasoline, petroleum-based products, or any strong solvents to clean your tool.

SPECIFIC SAFETY RULES

Additional Rules for Safe Operation

- **Know your power tool.** Read operator's manual carefully. Learn its applications and limitations as well as the specific potential hazards related to this tool. Following this rule will reduce the risk of electric shock, fire, or serious injury.
- **Always wear safety glasses with side shields.** Everyday eyeglasses have only impact resistant lenses; they are **NOT** safety glasses.
- **Protect your lungs.** Wear a face or dust mask if the operation is dusty.
- **Protect your hearing.** Wear hearing protection during extended periods of operation.
- **Hold tool by insulated gripping surfaces when performing an operation where the cutting tool may contact hidden wiring or its own cord.** Contact with a "live" wire will make exposed metal parts of the tool "live" and shock the operator.
- **Inspect tool cords periodically** and if damaged, have repaired at your nearest authorized service center. Stay constantly aware of cord location.
- **Check damaged parts.** Before further use of the tool, a guard or other part that is damaged should be carefully checked to determine that it will operate properly and perform its intended function. Check for alignment of moving parts, binding of moving parts, breakage of parts, mounting, and any other conditions that may affect its operation. A guard or other part that is damaged should be properly repaired or replaced by an authorized service center. Following this rule will reduce the risk of electric shock, fire, or serious injury.
- **Do not abuse cord. Never carry tool by cord or yank it to disconnect from receptacle. Keep cord from heat, oil and sharp edges.** Following this rule will reduce the risk of electric shock or fire.

- **Make sure your extension cord is in good condition.** When using an extension cord, be sure to use one heavy enough to carry the current your product will draw. A wire gage size (A.W.G.) of at least **16** is recommended for an extension cord 100 feet or less in length. A cord exceeding 100 feet is not recommended. If in doubt, use the next heavier gage. The smaller the gage number, the heavier the cord. An undersized cord will cause a drop in line voltage resulting in loss of power and overheating.
- **Drugs, Alcohol, Medication.** Do not operate tool while under the influence of drugs, alcohol, or any medication. Following this rule will reduce the risk of electric shock, fire, or serious injury.
- **Save these instructions.** Refer to them frequently and use them to instruct others who may use this tool. If you loan someone this tool, loan them these instructions also.

WARNING:

Some dust created by power sanding, sawing, grinding, drilling, and other construction activities contains chemicals known to cause cancer, birth defects or other reproductive harm. Some examples of these chemicals are:



- lead from lead-based paints,
- crystalline silica from bricks and cement and other masonry products, and
- arsenic and chromium from chemically-treated lumber.

Your risk from these exposures varies, depending on how often you do this type of work. To reduce your exposure to these chemicals: work in a well ventilated area, and work with approved safety equipment, such as those dust masks that are specially designed to filter out microscopic particles.

SAVE THESE INSTRUCTIONS

SYMBOLS

Important: Some of the following symbols may be used on your tool. Please study them and learn their meaning. Proper interpretation of these symbols will allow you to operate the tool better and safer.

SYMBOL	NAME	EXPLANATION
V	Volts	Voltage
A	Amperes	Current
Hz	Hertz	Frequency (cycles per second)
W	Watt	Power
min	Minutes	Time
~	Alternating Current	Type or a characteristic of current
≡	Direct Current	Type or a characteristic of current
n_0	No Load Speed	Rotational speed, at no load
	Class II Construction	Designates double-insulated construction tools
.../min	Revolutions or Reciprocation Per Minute	Revolutions, strokes, surface speed, orbits etc. per minute
	Safety Alert	Indicates danger, warning or caution. It means attention!!! Your safety is involved.
	Wet Conditions Alert	Do not expose to rain or use in damp locations.

The purpose of safety symbols is to attract your attention to possible dangers. The safety symbols, and the explanations with them, deserve your careful attention and understanding. The safety warnings do not by themselves eliminate any danger. The instructions or warnings they give are not substitutes for proper accident prevention measures.

Symbol	Meaning
--------	---------



DANGER: Indicates an imminently hazardous situation which, if not avoided, will result in death or serious injury.



WARNING: Indicates a potentially hazardous situation which, if not avoided, could result in serious injury.



CAUTION: Indicates a potentially hazardous situation which, if not avoided, may result in minor or moderate injury.

NOTE: Advises you of information or instructions vital to the operation or maintenance of the equipment.

UNPACKING

Your trimmer has been shipped completely assembled and ready for use. After removing it from the carton, inspect it carefully to make sure no breakage or damage has occurred during shipping. If any parts are damaged or missing, contact your nearest Ryobi dealer to obtain replacement parts before attempting to operate trimmer. A subbase accessory with handles, operator's manual, warranty registration and two wrenches are included in the carton.



WARNING:

If any parts are missing do not operate your trimmer until the missing parts are replaced. Failure to do so could result in possible serious injury.

FEATURES

KNOW YOUR TRIMMER

See Figure 2.

Before attempting to use your trimmer, familiarize yourself with all operating features and safety requirements.

Your trimmer is a versatile woodworking tool which will give you years of trouble-free performance. It is engineered with the professional in mind, but its ease of operation allows the amateur to produce work which is beautiful and precise.

As the name implies your trimmer can be used for trimming laminates. When used with recommended accessories, such as a straight guide, trimmer guide, template guide, or combination panel bit, it becomes even more versatile.



WARNING:

Do not allow familiarity with your trimmer to make you careless. Remember that a careless fraction of a second is sufficient to inflict severe injury.

HEAVY DUTY MOTOR

Your trimmer has a powerful 3.8 amp motor with sufficient power to handle many trimming jobs. It is capable of delivering 3/4 horsepower for heavy duty performance. The motor also has removable brushes for ease of servicing.

SWITCH

To turn your trimmer **ON**, slide the switch on top of the trimmer to **ON** position. Return the switch to **OFF** position when finished.

DEPTH OF CUT SCALE

Your trimmer's cutting depth can be adjusted by using the depth of cut scale. To adjust to desired depth of cut, loosen the wing bolt and move the base until the tip of the cutter touches work surface. The depth of cut is zero at this point. Position your trimmer so that the cutter can extend below the subbase for desired depth of cut setting. Move the base further until the mark on the depth of cut scale corresponds with your desired depth of cut. Then securely tighten the wing bolt.

ELECTRICAL CONNECTION

Your trimmer has a precision built electric motor. It should be connected to a **power supply that is 120 volts, 60 Hz, AC only (normal household current)**. Do not operate this tool on direct current (DC). A substantial voltage drop will cause a loss of power and the motor will overheat. If your tool does not operate when plugged into an outlet, double-check the power supply.



WARNING:

The operation of any trimmer can result in foreign objects being thrown into your eyes, which can result in severe eye damage. Before starting power tool operation, always wear safety goggles or safety glasses with side shields and a full face shield when needed. We recommend wide vision safety mask for use over eyeglasses or standard safety glasses with side shields.



WARNING:

Do not attempt to modify this tool or create accessories not recommended for use with this tool. Any such alteration or modification is misuse and could result in a hazardous condition leading to possible serious personal injury.

APPLICATIONS

(Use only for the purpose listed below)

- Smooth, professional trimming of laminates.
- Cabinet making, trimming counter tops, and finishing work.
- Trimming wood and plastics.

BALL BEARING PILOTED CUTTER

See Figures 1 and 5.

Use of ball bearing piloted trimmer cutters provide a convenient method of laminate trimming. Guide the ball bearing surface along the edge of workpiece. Be careful to follow instructions for correct direction of feed.

FEATURES

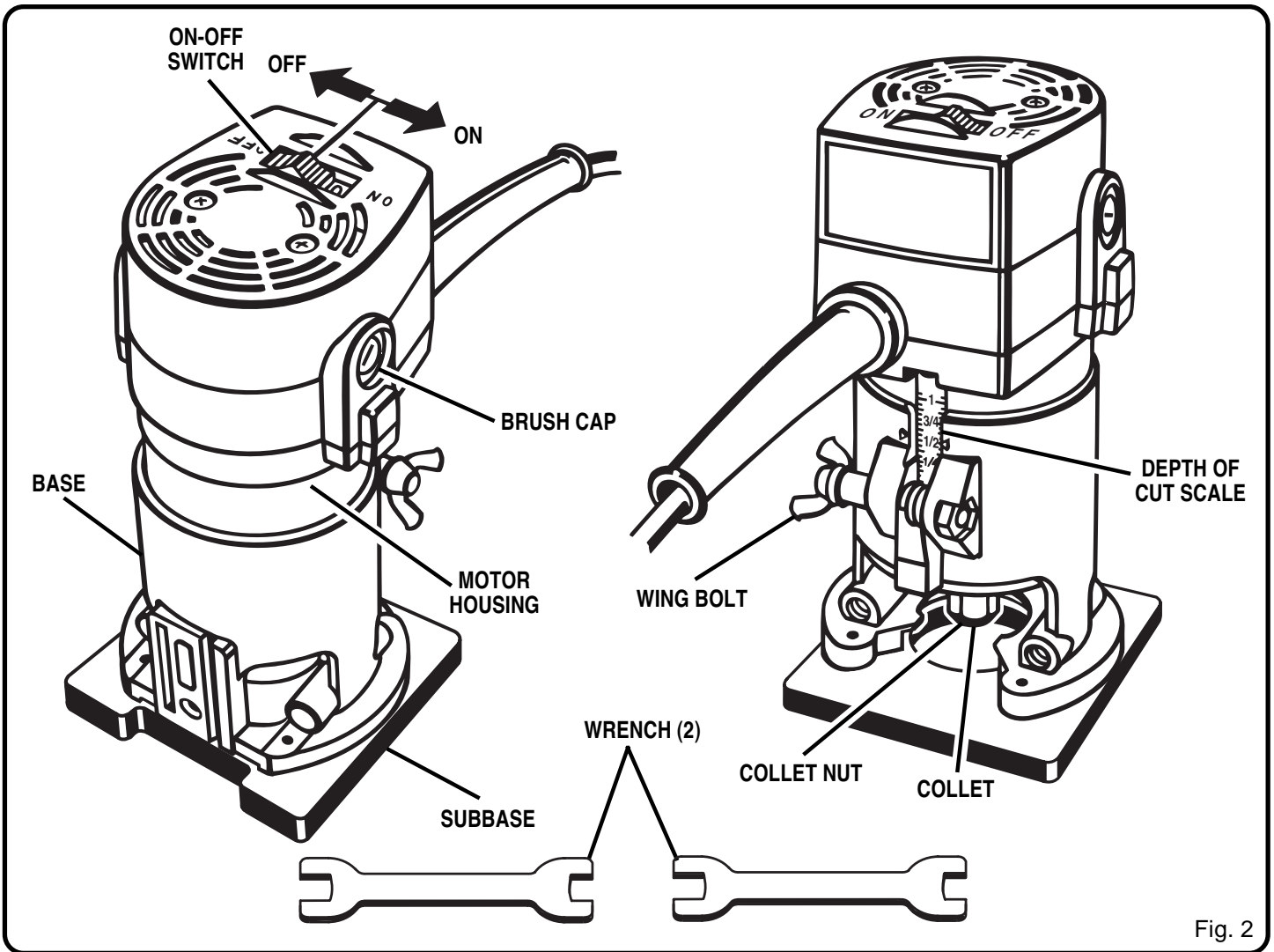

Fig. 2

ADJUSTMENTS

WARNING:

Your laminate trimmer should never be connected to power supply when you are assembling parts, making adjustments, installing or removing cutters, or when not in use. Disconnecting your trimmer will prevent accidental starting that could cause serious injury.

WARNING:

Do not use cutters with undersized shanks. Undersized shanks will not tighten properly and could be thrown from tool causing injury.

WARNING:

Do not use cutters that are larger in diameter than the opening in trimmer base. Use of such cutters will come in contact with the trimmer base and damage both the cutter and trimmer base. This situation could also cause possible loss of control or create other hazardous conditions that could cause possible serious personal injury.

ADJUSTMENTS

INSTALLING/REMOVING CUTTERS

See Figure 3.

■ UNPLUG YOUR TRIMMER.

WARNING:

Failure to unplug your trimmer could result in accidental starting causing serious injury.

- Place your trimmer upside down on a workbench in order to gain easy access to the spindle and collet nut.
- Place the small end of one of the wrenches provided on the spindle flats. This will hold the spindle stationary.
- Place the large end of the other wrench provided onto the collet nut. Rotate wrench counterclockwise to loosen collet nut. See Figure 3.

WARNING:

If you are changing a cutter immediately after use, be careful not to touch the cutter or collet with your hands or fingers. They will get burned because of the heat buildup from cutting. Always use the wrench provided.

- If installing cutter for the first time, it can be installed once collet nut is loose. If changing cutters, cutter will easily slip from collet after loosening collet nut.
- The collet is machined to precision tolerances to fit cutters with 1/4 in. (6.4 mm) diameter shanks.
- With your trimmer still upside down on a workbench, insert shank of cutter into collet. The shank of your cutter should be close to but not touching bottom of collet. This allows for expansion when the cutter gets hot.
- Tighten the collet nut securely by turning clockwise with the wrench provided. See Figure 3.

WARNING:

If collet nut is not tightened securely, cutter may come out during use, causing serious personal injury.

WARNING:

Avoid open area of trimmer base. Serious personal injury will result from contact with a rotating cutter.

TO SET DEPTH OF CUT

See Figure 4.

■ UNPLUG YOUR TRIMMER.

WARNING:

Failure to unplug your trimmer could result in accidental starting causing serious injury.

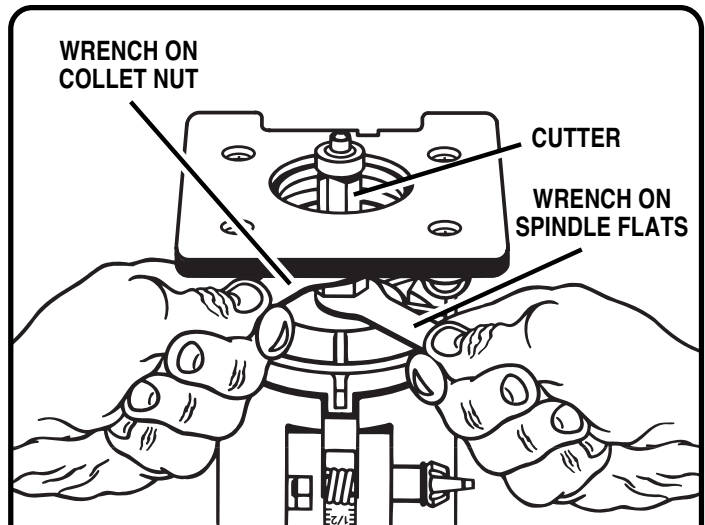

Fig. 3

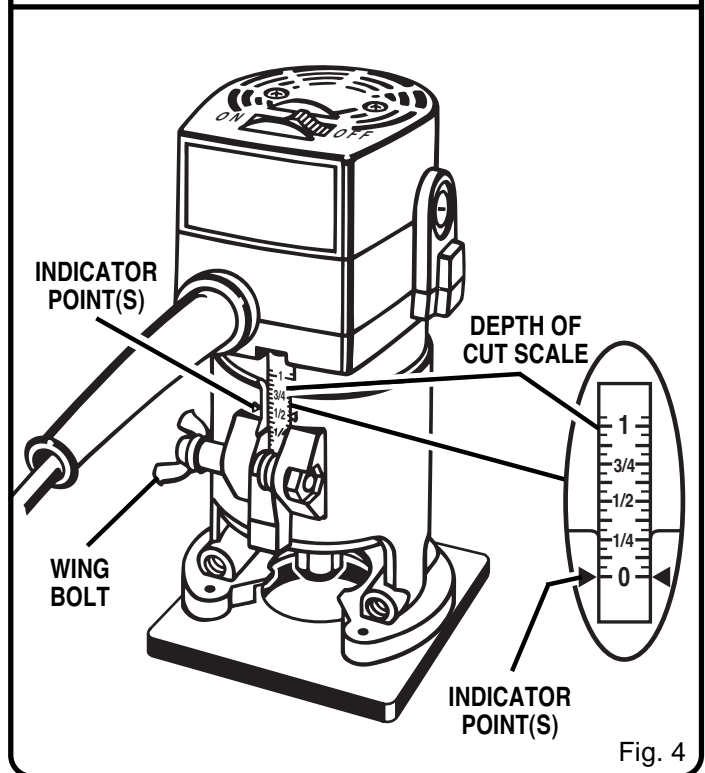

Fig. 4

- Loosen the wing bolt and move the base until the tip of cutter touches the work surface. The depth of cut is zero at this point. See Figure 4.
- Position your trimmer so that the cutter can extend below the subbase for desired depth of cut setting.
- Move the base to obtain the desired depth of cut. The distance the cutter moves can be read on the depth of cut scale. Each mark on the scale indicates a 1/16 in. (1.6 mm) change in depth setting. Indicator points are located on the base.
- Securely tighten the wing bolt.

OPERATION

WARNING:

Always wear safety goggles or safety glasses with side shields when using your trimmer. Failure to do so could result in dust, shavings, chips, loose particles, or foreign objects being thrown into your eyes resulting in possible serious injury. If the operation is dusty, also wear a face or dust mask.

WARNING:

When turning your trimmer **ON**, be prepared for start-up torque. Always have a firm grasp of your trimmer before starting. Because of the high cutter speed rotation your trimmer has a tendency to twist, jerk, or grab in your hands during start-up. If not prepared, this can cause a loss of control resulting in possible serious injury.

HOW TO OPERATE YOUR TRIMMER

Before starting your trimmer, unplug it and make sure cutter is securely tightened in collet and that depth of cut is properly set. **Never start trimmer while cutter is in contact with the workpiece.**

After completing a cut, **pull** cutter slightly away from cut surface. **Turn trimmer off** and **wait** for rotating cutter to completely stop before removing base from work surface.

Your trimmer is turned on by means of a slide switch located on top of the tool. Make a few cuts on a piece of scrap material to determine the desired depth or shape of cut. When cutting, fit the base of your trimmer over the work surface and firmly hold the body of your trimmer with your hand. Make sure the trimmer is running at full speed. For best results, move your trimmer from left to right, against the turning direction of the cutter. See *Figure 5*. Be sure not to move trimmer too rapidly.

Remain alert and watch what you are doing. **DO NOT** operate trimmer when fatigued or under the influence of drugs, alcohol, or any medication.

FEED DIRECTION

When trimming, the cutter rotates clockwise. Therefore, you should feed the trimmer into the workpiece from left to right. When fed from left to right, the rotation of the cutter pulls the trimmer against the workpiece. If fed in the opposite direction, the rotation forces of the spinning cutter will tend to throw the trimmer away from the workpiece. This could cause loss of control of your trimmer.

RATE OF FEED

IMPORTANT: The whole “secret” of professional laminate trimming lies in making a careful setup for the cut to be made and in selecting the proper rate of feed.

The proper rate of feed depends on several factors: the hardness and moisture content of the workpiece, the depth of

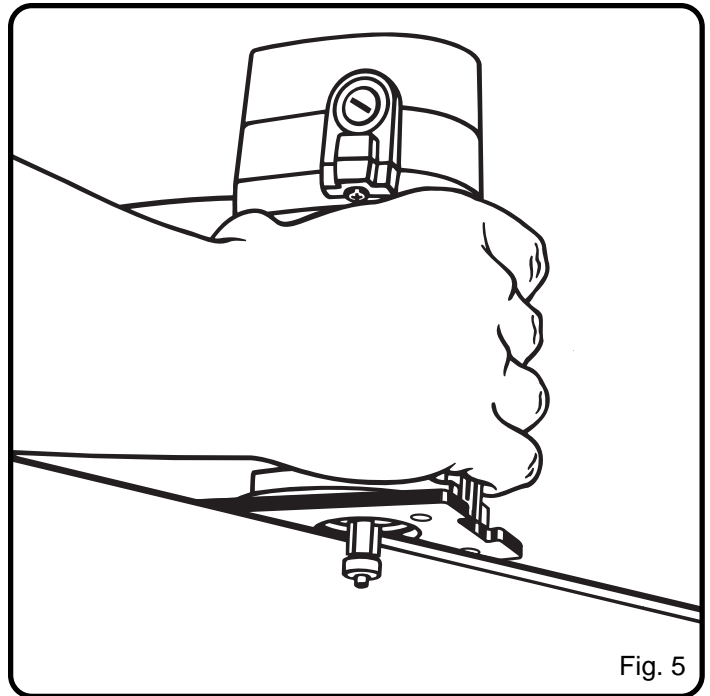

Fig. 5

cut, and the cutting diameter of the cutter. When cutting shallow grooves in soft woods such as pine, a faster rate of feed can be used. When making cuts in hardwoods such as oak, a slower rate of feed will be required.

The best rate of feed is one that does not slow down the trimmer motor more than one-third of its no-load speed. If the trimmer is fed too fast, it will take large chips out of the wood and leave gouge marks. If the trimmer is fed too slow, it will scorch or burn the wood.

PROPER FEEDING

The right feed is neither too fast nor too slow. It is the rate at which the cutter is being advanced firmly and surely to produce a continuous spiral of uniform chips or a smooth trim edge on laminate. If you are making a small diameter, shallow groove in soft, dry wood, the proper feed may be about as fast as you can travel your trimmer along your guide line. On the other hand, if the cutter is a large one, the cut is deep or the workpiece is hard to cut, the proper feed may be a very slow one. A cross-grain cut may require a slower pace than an identical with-grain cut in the same workpiece.

There is no fixed rule. You will learn by experience from practice and use. The best rate of feed is determined by listening to the sound of the trimmer motor and by feeling the progress of each cut. Always test a cut on a scrap piece of the workpiece wood or laminate beforehand.

FORCE FEEDING

Clean, smooth laminate trimming and edge shaping can be done only when the cutter is revolving at a relatively high speed and is taking very small bites to produce tiny, cleanly severed chips. If your trimmer is forced to move forward too fast, the speed of the cutter becomes slower than normal in relation to its forward movement. As a result, the cutter must take bigger bites as it revolves. “Bigger bites” mean bigger

OPERATION

chips, and a rougher finish. Bigger chips also require more power, which could result in the trimmer motor becoming overloaded.

Under extreme force-feeding conditions the relative speed of the cutter can become so slow — and the bites it has to take so large — that chips will be partially knocked off (rather than fully cut off), with resulting splintering and gouging of the workpiece. See Figure 6.

Your trimmer is an extremely high-speed tool (23,000 RPM no-load speed), and will make clean, smooth cuts if allowed to run freely without the overload of a forced (too fast) feed. Three things that cause “force feeding” are cutter size, depth-of-cut, and workpiece characteristics. The larger the cutter or the deeper the cut, the more slowly the trimmer should be moved forward. If the wood is very hard, knotty, gummy or damp, the operation must be slowed still more.

You can always detect “force feeding” by the sound of the motor. Its high-pitched whine will sound lower and stronger as it loses speed. Also, the strain of holding the tool will be noticeably increased.

TOO SLOW FEEDING

It is also possible to spoil a cut by moving the trimmer forward too slowly. When it is advanced into the work too slowly, a revolving cutter does not dig into new wood fast enough to take a bite; instead, it simply scrapes away sawdust-like particles. Scraping produces heat, which can glaze, burn, or mar the cut — in extreme cases, it can even overheat the cutter so as to destroy its hardness. Dull cutters can also contribute to scraping and burning.

In addition, it is more difficult to control a trimmer when the cutter is scraping instead of cutting. With practically no load on the motor the cutter will be revolving at close to top RPM, and will have a much greater than normal tendency to bounce off the sides of the cut (especially, if the wood has a pronounced grain with hard and soft areas). As a result, the cut produced may have sides that are rippled instead of straight.

“Too-slow feeding” can also cause your trimmer to take off in a wrong direction from the intended line of cut. You can detect “too-slow feeding” by the high-pitched sound of the motor. **Always grasp and hold your trimmer firmly when trimming.**

DEPTH OF CUT

See Figure 7.

As previously mentioned, the depth of cut is important because it affects the rate of feed which, in turn, affects the quality of a cut (and, also, the possibility of damage to your trimmer motor and cutter). A deep cut requires a slower feed than a shallow one, and a too deep cut will cause you to slow the feed so much that the cutter is no longer cutting, it is scraping, instead.

Making a deep cut is never advisable. The smaller cutters— especially those only 1/16 in. (1.6 mm) in diameter — are easily broken off when subjected to too much side thrust. A

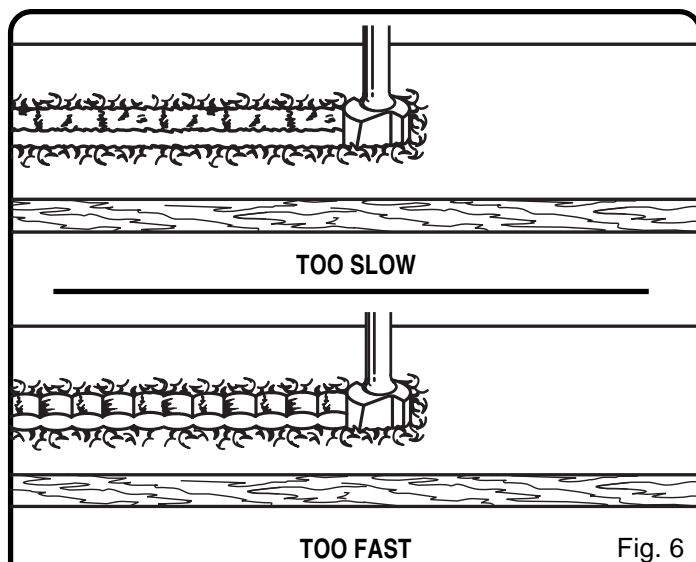

Fig. 6

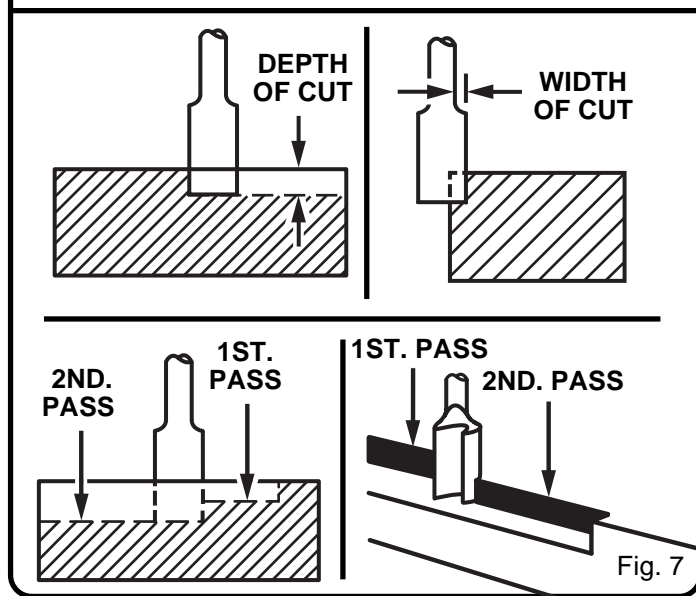

Fig. 7

large enough cutter may not be broken off, but if the cut is too deep a rough cut will result — and it may be very difficult to guide and control the cutter as desired. For these reasons, we recommend that you do not exceed 1/8 in. (3.2 mm) depth of cut in a single pass, regardless of the cutter size or the softness or condition of the workpiece. This will result in a higher quality cut.

To make deeper cuts it is therefore necessary to make as many successive passes as required, lowering the cutter 1/8 in. (3.2 mm) for each new pass. In order to save time, do all the cutting necessary at one depth setting, before lowering the cutter for the next pass. This will also assure a uniform depth when the final pass is completed.

WARNING:

If desired depth of cut is greater than can be safely cut in one pass, make cuts in two or more passes.

OPERATION

DIRECTION OF FEED AND THRUST

See Figures 8 and 9.

The trimmer motor and cutter revolve in a clockwise direction. This gives the tool a slight tendency to twist (in your hands) in a counterclockwise direction, especially when the motor starts.

Because of the extremely high speed of cutter rotation during a “proper feeding” operation, there is very little kickback to contend with under normal conditions. However, should the cutter strike a knot, hard grain, foreign object, etc. that would affect the normal progress of the cutting action, there will be a slight kickback — sufficient to spoil the trueness of your cut if you are not prepared. Such a kickback is always in the direction opposite to the direction of cutter rotation.

To guard against such a kickback, plan your setup and direction of feed so that you will always be thrusting the tool — to hold it against whatever you are using to guide the cut — in the same direction that the leading edge of the cutter is moving. In short, the thrust should be in a direction that keeps the sharp edges of the cutter continuously biting straight into new (uncut) wood.

EXTENSION CORDS

The use of any extension cord will cause some loss of power. To keep the loss to a minimum and to prevent tool overheating, use an extension cord that is heavy enough to carry the current the tool will draw.

A wire gage size (A.W.G.) of at least **16** is recommended for an extension cord 100 feet or less in length. When working outdoors, use an extension cord that is suitable for outdoor use. The cord's jacket will be marked **WA**.



CAUTION:

Keep extension cords away from any trimming area and position the cord so that it will not get caught on lumber, tools, etc., during trimming operation.



WARNING:

Check extension cords before each use. If damaged replace immediately. Never use tool with a damaged cord since touching the damaged area could cause electrical shock resulting in serious injury.

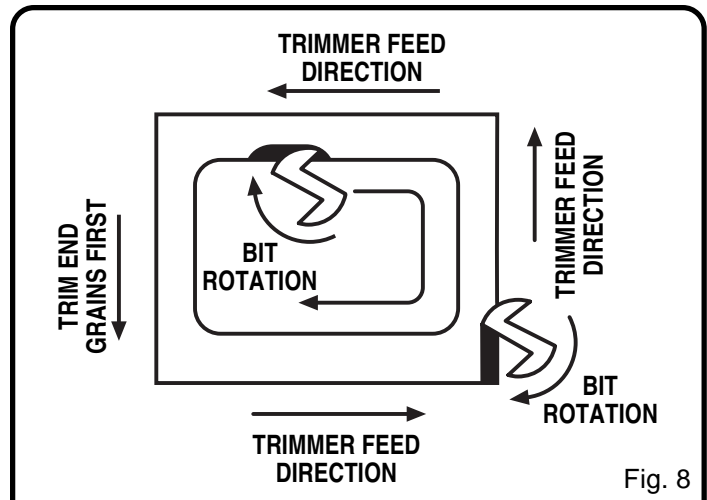

Fig. 8

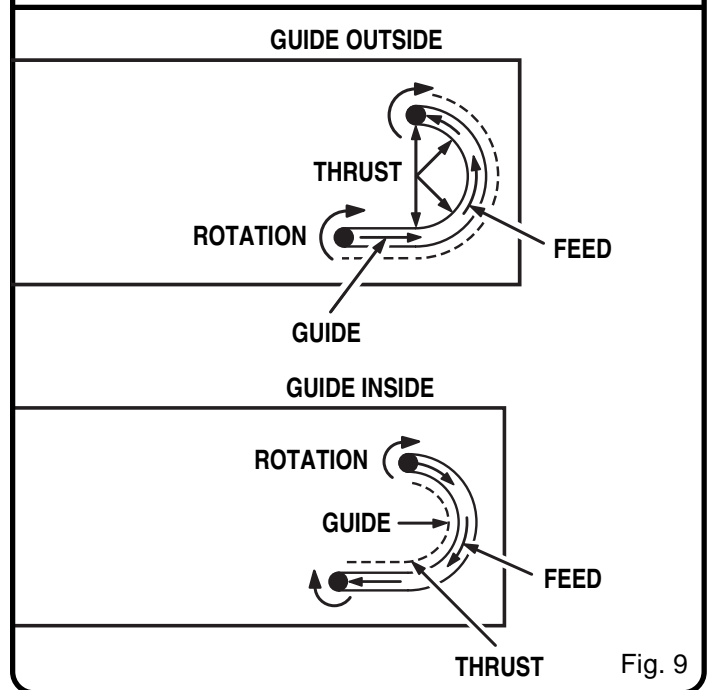

Fig. 9

MAINTENANCE

WARNING:

When servicing use only identical Ryobi replacement parts. Use of any other parts may create a hazard or cause product damage.

BRUSH REPLACEMENT

See Figure 10.

Your trimmer has externally accessible brush assemblies that should periodically be checked for wear. **Proceed as follows when replacement is required:**

■ UNPLUG YOUR TRIMMER.

WARNING:

Failure to unplug your trimmer could result in accidental starting causing serious injury.

- Remove brush cap with a flat blade screwdriver. Brush assembly is spring loaded and will pop out when you remove brush cap.
- Remove brush assembly (brush and spring).
- Check for wear. If worn, always replace in pairs. **DO NOT** replace one side without replacing the other.
- Reassemble using new brush assemblies. Make sure curvature of brush matches curvature of motor and that brush moves freely in brush tube.
- Make sure brush cap is oriented correctly (straight) and replace.
- Tighten brush cap securely. **DO NOT** over torque.

PROPER CARE OF CUTTERS

Get faster more accurate cutting results by keeping cutters clean and sharp. Remove all accumulated pitch and gum from cutters after each use.

When sharpening cutters, sharpen only the inside of the cutting edge. Never grind the outside diameter. Be sure when sharpening the end of a cutter to grind the clearance angle the same as originally ground.

PROPER CARE OF COLLET

From time to time, it also becomes necessary to clean your collet and collet nut. To do so, simply remove collet nut from collet and clean the dust and chips that have collected. Then return collet nut to its original position.

GENERAL

Avoid using solvents when cleaning plastic parts. Most plastics are susceptible to damage from various types of commercial solvents and may be damaged by their use. Use clean cloths to remove dirt, carbon dust, etc.

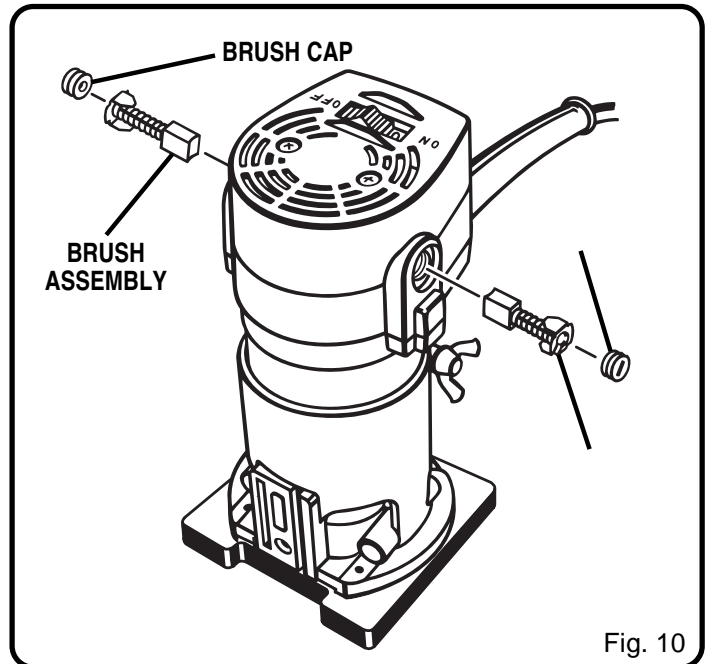

Fig. 10

WARNING:

Do not at any time let brake fluids, gasoline, petroleum-based products, penetrating oils, etc. come in contact with plastic parts. They contain chemicals that can damage, weaken, or destroy plastic.

When electric tools are used on fiberglass boats, sports cars, wallboard, spackling compounds, or plaster, it has been found that they are subject to accelerated wear and possible premature failure, as the fiberglass chips and grindings are highly abrasive to bearings, brushes, commutators, etc. Consequently it is not recommended that this tool be used for extended work on any fiberglass material, wallboard, spackling compounds, or plaster. During any use on these materials, it is extremely important that the tool is cleaned frequently by blowing with an air jet.

WARNING:

Always wear safety goggles, or safety glasses with side shields during power tool operation or when blowing dust. If operation is dusty, also wear a dust mask.

LUBRICATION

All of the bearings in this tool are lubricated with a sufficient amount of high grade lubricant for the life of the unit under normal operating conditions. Therefore, no further lubrication is required.

ACCESSORIES

HELPFUL HINTS

- ✓ Always clamp workpiece securely before trimming.
- ✓ A safe operator is one who thinks ahead.
- ✓ Always wear eye protection when trimming.
- ✓ Make setup adjustments carefully. Then double check. Measure twice and cut once.
- ✓ Keep cutters clean and properly sharpened.
- ✓ Don't let familiarity make you careless.
- ✓ Study all safety rules and do the job safely.
- ✓ **NEVER** place your hands in jeopardy.
- ✓ Make certain clamps can't loosen while in use.
- ✓ Test difficult setups on scrap — Don't waste lumber.
- ✓ Plan each operation before you begin.
- ✓ Provide for smoother operation by cleaning your trimmer frequently. Shake trimmer or blow with an air jet to remove sawdust buildup.
- ✓ **THINK SAFETY BY THINKING AHEAD.**

EDGE SHAPING WITH OPTIONAL TRIMMER GUIDE

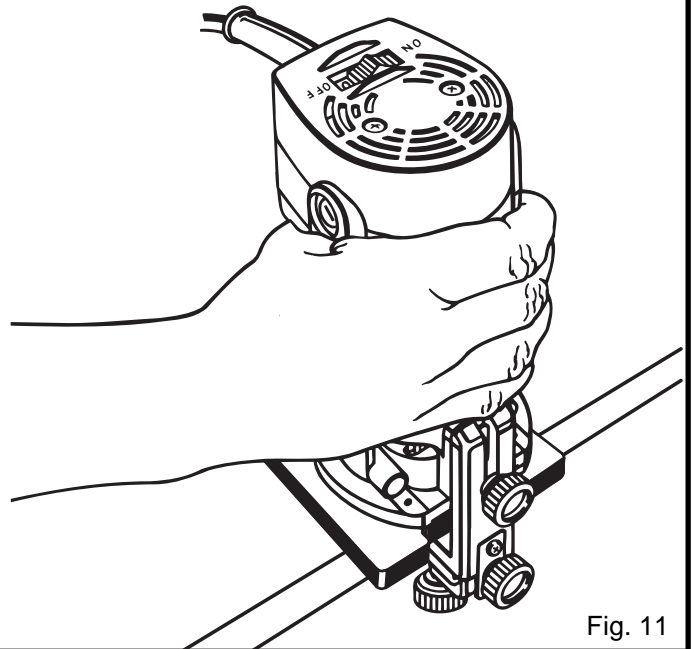

Fig. 11

Standard accessories included with your laminate trimmer are two wrenches. A subbase accessory with two handles is also included.

The following is a list of optional accessories available for your Laminate Trimmer:

Part No.	Description
6072373	Trimmer Guide
4675208	Straight Trim Bit
6072063	Straight Guide

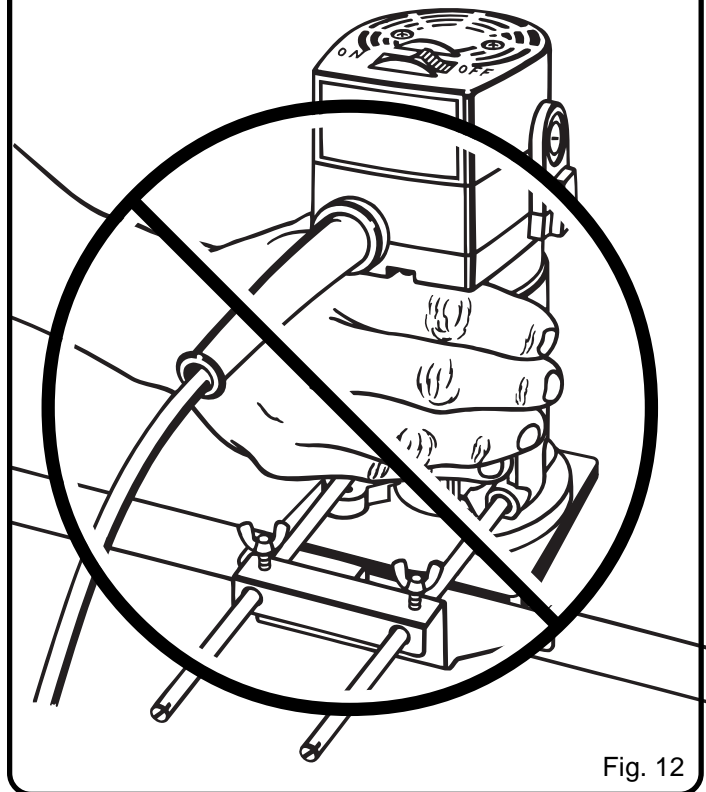

Fig. 12



WARNING:

Avoid hand positions that may expose fingers to cutter through open areas of trimmer base. See Figure 12.

ACCESSORIES

TRIMMING WITH SUBBASE ACCESSORY

See Figures 13 and 16.

A subbase accessory is packed in the box with your trimmer. If desired, the existing subbase can be removed and this accessory attached.

It is convenient when routing 4 in. (101.6 mm), 5 in. (127 mm), or 6 in. (152.4 mm) circular grooves. It can also be used when routing grooves parallel to the edge of the workpiece.

The handles provided allow you to grasp and hold your trimmer with two hands similar to grasping and holding a router.

TO ATTACH SUBBASE ACCESSORY

See Figure 13.

- Unplug your trimmer.



WARNING:

Failure to unplug your trimmer could result in accidental starting causing serious injury.

- Turn your laminate trimmer upside down, remove the four subbase screws and subbase.
- Attach your subbase accessory using the same four subbase screws.
- Tighten subbase screws securely, but do not overtighten.
- Turn your laminate trimmer upright and thread the handles provided into the threaded holes in the subbase accessory.
- Tighten handles securely.

ROUTING GROOVES IN A CIRCLE

See Figure 14.

- There are three holes marked R2", R2-1/2", and R3" on the subbase accessory. Each number represents a radius and may be used when cutting circular grooves that are 4 in. (101.6 mm), 5 in. (127 mm) or 6 in. (152.4 mm) in diameter.
- Select the radius for the desired circle, place a finishing nail through the hole and securely tack it into your workpiece. This will create a pivot axis for that size radius.
- Rout circular groove in a clockwise direction only. See arrow shown in figure 14.

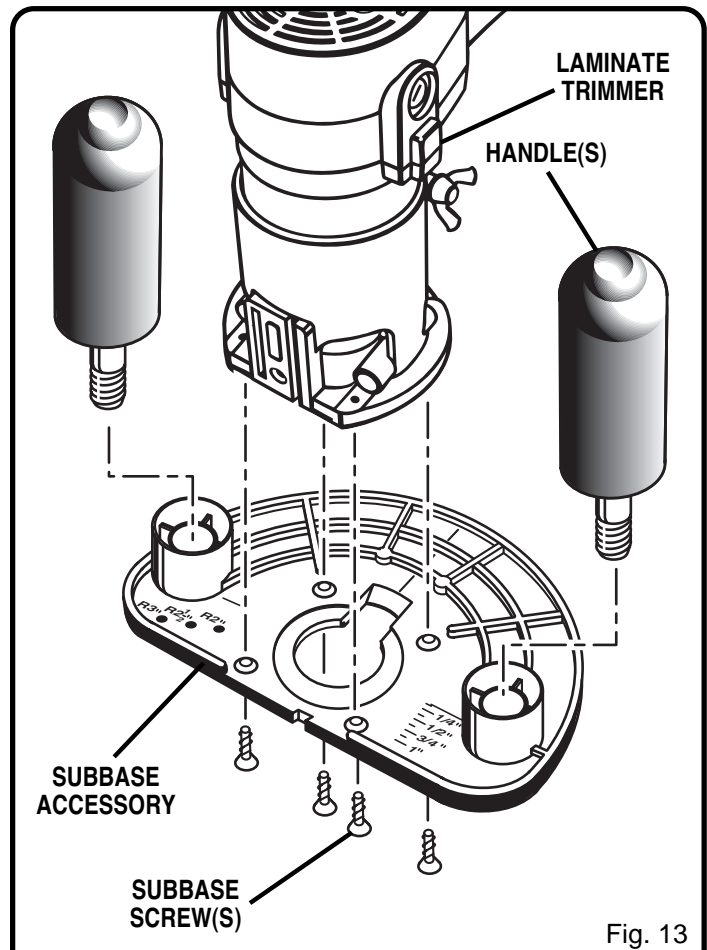

Fig. 13

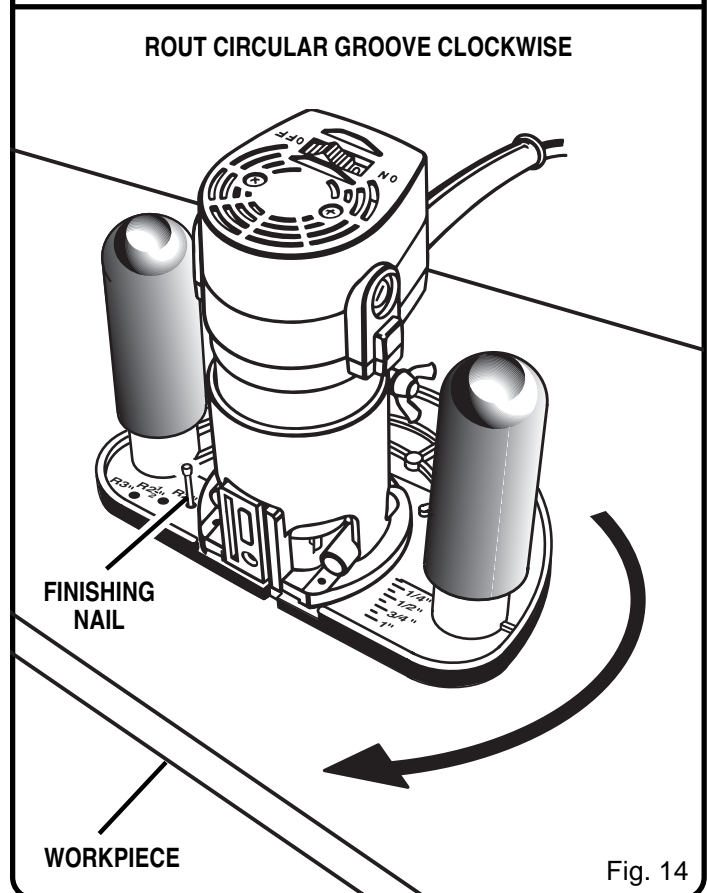

Fig. 14

ACCESSORIES

ROUTING GROOVES PARALLEL TO AN EDGE

See Figures 13 and 14.

You can use the scale provided on the subbase accessory to cut a straight parallel line up to 1 in. (25.4 mm) from the edge of your workpiece.

- The intersection of the horizontal and vertical lines at the center of the subbase accessory indicates the center of your cutter. This is also the center of groove being cut.
- If you have purchased an optional straight guide, place cutter at desired position on the workpiece and make your cut from left to right as shown by the arrow in figure 13.
- In this case the thrust is from straight guide towards the cutter or trimmer.
- For grooves more than 1 in. (25.4 mm) from the edge of workpiece, align the center of desired groove on workpiece with centerline on subbase accessory. Then measure from the centerline on subbase accessory to the guiding portion of straight guide. Tighten knob on the straight guide securely.
- If you are using "C" clamps and a board to act as your straight edge, place cutter at desired position on the workpiece and make your cut from right to left as shown by the arrow in figure 16.
- **Note:** The board being used as a straight edge must be 1/4 in. (6.4 mm) thick or less to prevent contact with trimmer base. It must also be at least as long as the workpiece in order to be a guide.
- In this case the thrust is from your trimmer against the straight edge.
- As mentioned previously, do not make too heavy of a cut in one pass. If a deep cut is required, make successive passes at increasing depths with each new pass until you reach the desired groove depth.

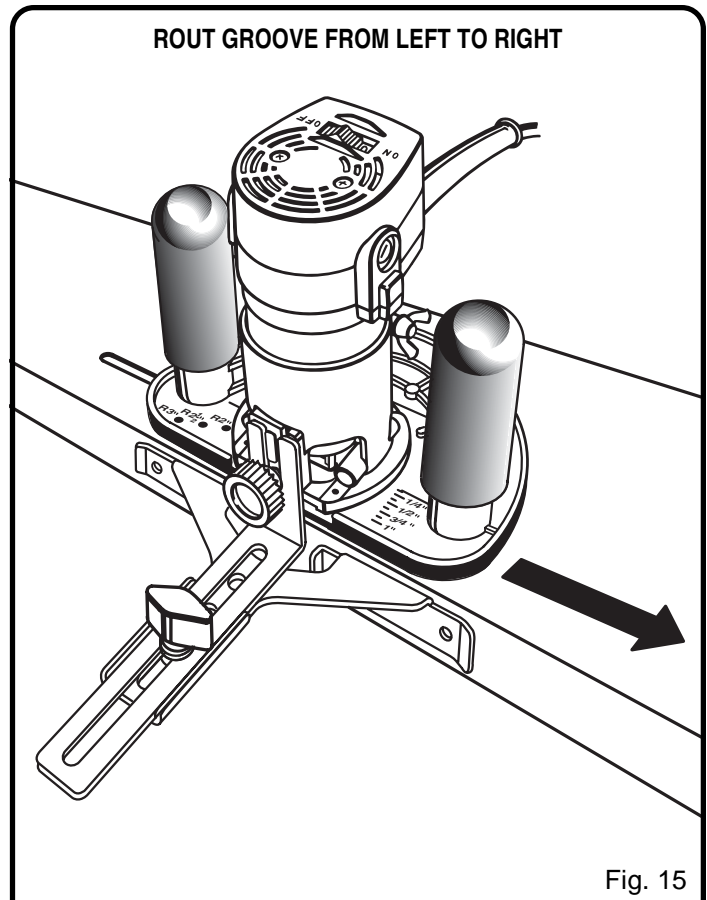

Fig. 15

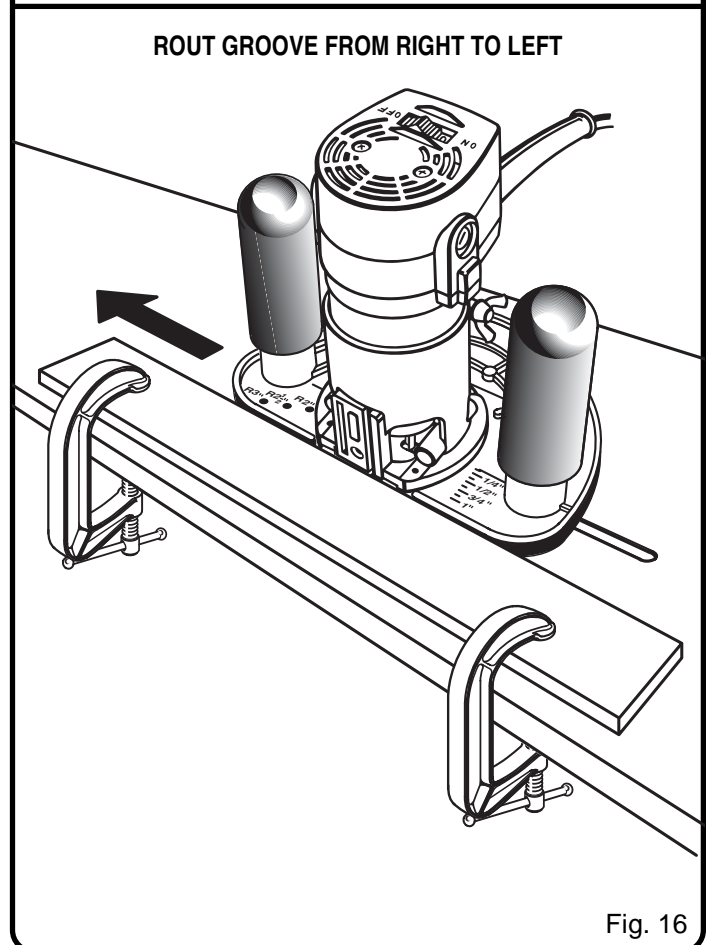

Fig. 16



OPERATOR'S MANUAL

LAMINATE TRIMMER - TR31-1

DOUBLE INSULATED

- **SERVICE**

Now that you have purchased your tool, should a need ever exist for repair parts or service, simply contact your nearest Ryobi Authorized Service Center. Be sure to provide all pertinent facts when you call or visit. Please call 1-800-525-2579 for your nearest Ryobi Authorized Service Center. You can also check our web site at www.ryobitools.com for a complete list of Authorized Service Centers.

- **MODEL NO. AND SERIAL NO.**

The model number of this tool will be found on a plate attached to the motor housing. Please record the model number and serial number in the space provided below.

- **HOW TO ORDER REPAIR PARTS**

WHEN ORDERING REPAIR PARTS,
ALWAYS GIVE THE FOLLOWING INFORMATION:

- MODEL NUMBER TR31-1
- SERIAL NUMBER _____

RYOBI TECHNOLOGIES, INC.

1428 Pearman Dairy Road Anderson, SC 29625
Post Office Box 1207 Anderson, SC 29622-1207
Phone 1-800-525-2579
www.ryobitools.com